

TECHNICAL SPECIFICATIONS

MLA2

Product Group: **MONARC™ Touring Class**
System Type: **2-way Linear Array**

FEATURES AND ADVANCES

- Seamless Vertical Coverage
- Consistent 100° Horizontal Beamwidth
- Ultra-Low Distortion Midrange via HX32™ Drivers
- Effortless Integrated Rigging and Transportation
- Extreme Waterproofing

PRODUCT DESCRIPTION

The MLA2 is a 2-way, axisymmetric, mid-size line array module based on McCauley Sound's innovative MONARC™ line array technology. The system is engineered to deliver high definition, high SPL sound reinforcement for a broad range of applications, including concert / touring sound and corporate events. Brilliant technologies like the Intercell Summation Aperture™ and the Hybrid Horn Phase Correction Device create a linear, coherent wide-band wavefront with extremely low distortion. This makes the MONARC™ MLA2 one of the most precise and acoustically transparent line array system on the market. At the same time, the MLA2 MONARC™ Integrated Rigging System provides operators with the easiest and fastest way to fly or stack a line array in the industry.

CONSTRUCTION

The enclosure is constructed of 12-ply void-free birch hardwood plywood and is coated with a weather and wear resistant ProCoat™ polyurea hybrid finish. All rigging components are weather protected with a heat cured epoxy powder coat finish. Components in the front of the enclosure are protected by a curved grill made from perforated steel that is coated with heat cured epoxy powder, and lined with acoustically transparent foam. Cam-Lock quick release fasteners allow easy access to the loudspeakers with only a screw driver.

APPLICATIONS

- Performing Arts Centers
- House of Worship Installation
- Touring Sound Reinforcement for Medium Sized Venues
- Sidefill and Downfill for MLA3 and MLA6

PERFORMANCE PARAMETERS

System Type	2-way Linear Array
Frequency Response	
-10dB	60Hz - 20kHz
+/- 3dB	80Hz - 15kHz
Sensitivity	
LF	101dB @ 2.83V 1 m
HF	110.5dB @ 2.83V 1 m
Maximum SPL	(cont. / peak)
LF	130dB / 136dB
HF	133dB / 139dB
Power Ratings	
LF - RMS	400w @ 8Ω
HF - RMS	100w @ 8Ω
LF - AES	800w @ 8Ω
HF - AES	200w @ 8Ω

PHYSICAL PROPERTIES

Weight	85lbs / 38.6kgs
Dimensions	
inches	10.97 H x 27.25 W x 23.5 D
centimeters	27.9 H x 69.3 W x 59.7 D
Enclosure Material	5/8" 12 ply Birch Laminate
Suspension	MONARC™ Integrated Rigging
Finish	Procoat™ Polyurea-Hybrid Weatherproofing (Black is standard, White and / or Custom Colors Available)
Transducers	
LF	(2) 8" Cone Transducers, 2" Voice Coil
HF	(2) 1.75" Diaphragm, 1" Exit Neodymium Compression Driver
Connectors	Neutrik™ Speakon NL8
pass-thru	Pins 1+ / 1- , Pins 2+ / 2-
MF	Pins 3+ / 3-
HF	Pins 4+ / 4-
Optional Accessories	MB2 (Rigging Frame For MLA2) MB2-S (Short Rigging Frame For MLA2) MCB2 (Caster Board For MLA2) MCV2 (Protective Cover For MLA2)



DIMENSIONAL ILLUSTRATIONS

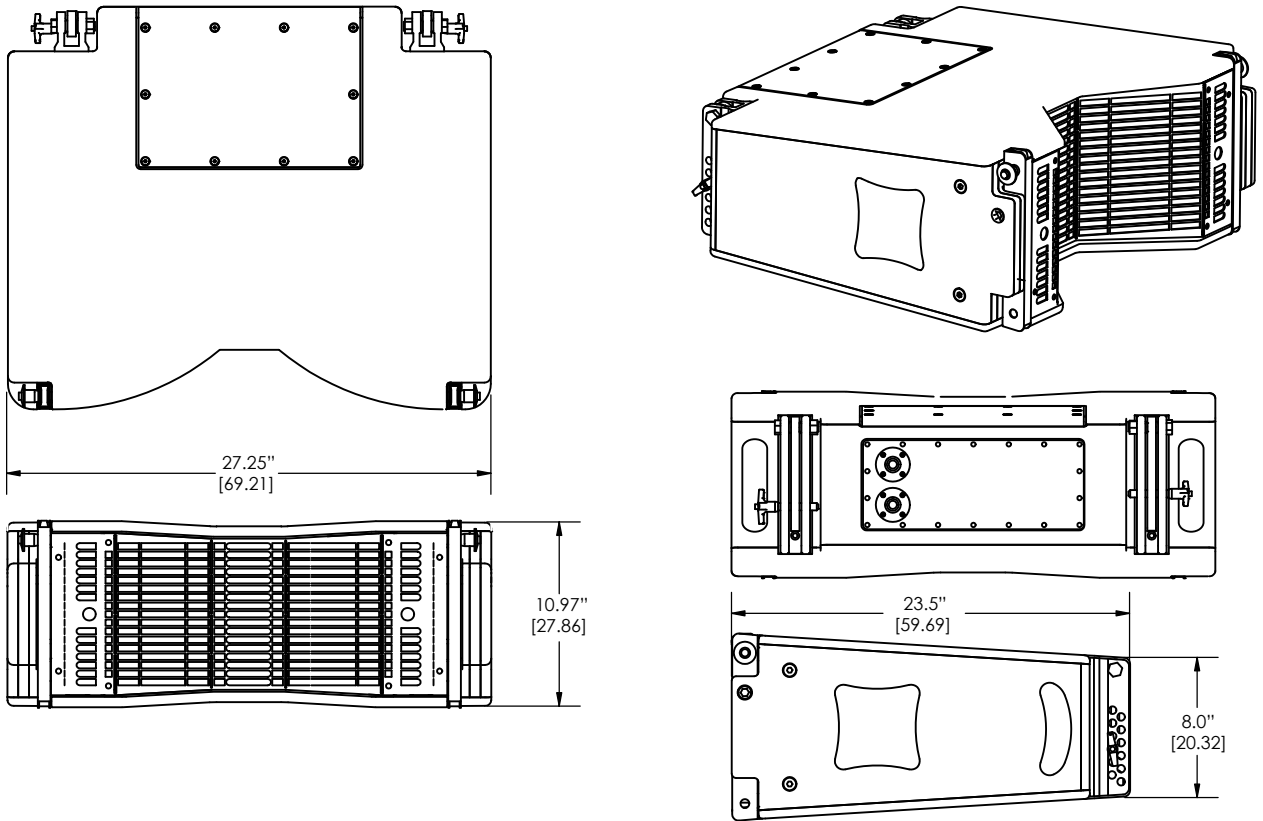

ARCHITECTS AND ENGINEERS SPECIFICATIONS

The two-way full range loudspeaker system shall incorporate two 2" (51 mm) voice coil, 8" (204 mm) diameter LF transducers and two 1" (25 mm) exit, 1.75" (45 mm) diaphragm HF compression drivers. The devices shall be loaded axisymmetric within the acoustic horn.

The high frequency transducer shall be mounted to a true constant directivity acoustic horn with a nominal horizontal coverage pattern of 100°. The vertical coverage pattern of the horn will vary with array height and curvature.

The LF transducers shall be mounted in an optimally vented enclosure tuned for maximum low frequency response. The midrange is extended via a Hybrid Horn Phase Correction Device within the constant directivity acoustic horn.

The system frequency response shall vary no more than ± 3 dB from 80 Hz to 15 kHz measured on axis. The low frequency transducers shall produce a Sound Pressure Level (SPL) of 101 dB SPL at a distance of 1 meter with an electrical power input of 1 Watt, and shall be capable of producing a maximum peak output of 136 dB SPL on axis at 1 meter. The high frequency transducer shall produce an acoustic Sound Pressure Level (SPL) of 110 dB SPL on axis at 1 meter with an electrical power input of 1 Watt, and shall be capable of producing a peak output of 139 dB SPL on axis at 1 meter.

Each low frequency transducer shall handle 400 Watts of amplifier power (per AES Standard AES2-1984-r2003) and shall have a nominal impedance of 8 Ohms. The high frequency transducer shall handle 100 Watts of amplifier power (per AES ref Standard AES2-1984-r2003) and shall have a nominal impedance of 8 Ohms.

The loudspeaker enclosure shall have a maximum weight of 85 lbs. (38.64 kg) and shall measure 10.97" (279 mm) high at front, 8" (204 mm) in height at rear, 27.25" (693 mm) wide, and 23.5" (597 mm) in depth. The enclosure top and bottom shall taper at 7° from a maximum frontal height, narrowing in the vertical plane toward the rear. The structure of the enclosure shall be constructed of 12-ply void-free birch hardwood plywood and shall have a weather and wear resistant ProCoat(tm) polyurea hybrid finish.

Input connectors shall be two, Neutrik Speakon NL8 locking connectors, wired together in parallel using AWG12 braided wire. Pins 1+, 1-, and 2+, 2- shall be wired to pass through between two connectors. Pins 3+, 3- shall be wired to the LF transducers, while Pins 4+, 4- shall be wired to the HF transducers.

Components in the front of the enclosure are to be protected by a compound-curved grill made from perforated steel that is coated with heat cured epoxy powder, and lined with acoustically transparent foam.

The 2-way full range loudspeaker shall be the McCauley Sound model MLA2.