

## POWERPOD 410 POWERED MIXER

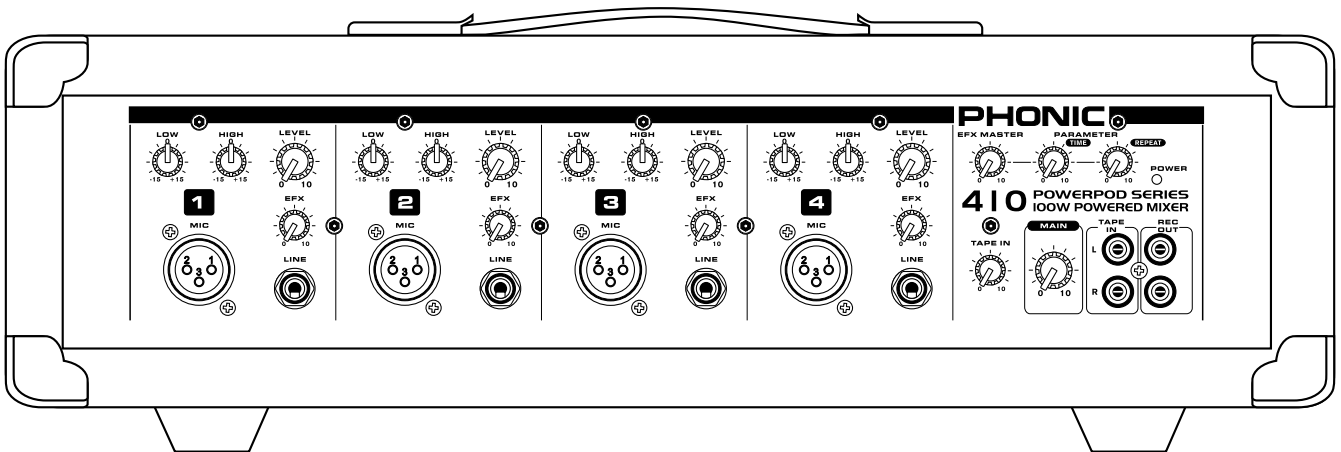

## IMPORTANT SAFETY INSTRUCTIONS

The apparatus shall not be exposed to dripping or splashing and that no objects filled with liquids, such as vases, shall be placed on the apparatus. The MAINS plug is used as the disconnect device, the disconnect device shall remain readily operable.

**Warning:** the user shall not place this apparatus in the confined area during the operation so that the mains switch can be easily accessible.

1. Read these instructions before operating this apparatus.
2. Keep these instructions for future reference.
3. Heed all warnings to ensure safe operation.
4. Follow all instructions provided in this document.
5. Do not use this apparatus near water or in locations where condensation may occur.
6. Clean only with dry cloth. Do not use aerosol or liquid cleaners. Unplug this apparatus before cleaning.
7. Do not block any of the ventilation openings. Install in accordance with the manufacturer's instructions.
8. Do not install near any heat sources such as radiators, heat registers, stoves, or other apparatus (including amplifiers) that produce heat.
9. Do not defeat the safety purpose of the polarized or grounding-type plug. A polarized plug has two blades with one wider than the other. A grounding type plug has two blades and a third grounding prong. The wide blade or the third prong is provided for your safety. If the provided plug does not fit into your outlet, consult an electrician for replacement of the obsolete outlet.
10. Protect the power cord from being walked on or pinched particularly at plug, convenience receptacles, and the point where they exit from the apparatus.
11. Only use attachments/accessories specified by the manufacturer.
12. Use only with a cart, stand, tripod, bracket, or table specified by the manufacturer, or sold with the apparatus. When a cart is used, use caution when moving the cart/apparatus combination to avoid injury from tip-over.
13. Unplug this apparatus during lightning storms or when unused for long periods of time.
14. Refer all servicing to qualified service personnel. Servicing is required when the apparatus has been damaged in any way, such as power-supply cord or plug is damaged, liquid has been spilled or objects have fallen into the apparatus, the apparatus has been exposed to rain or moisture, does not operate normally, or has been dropped.

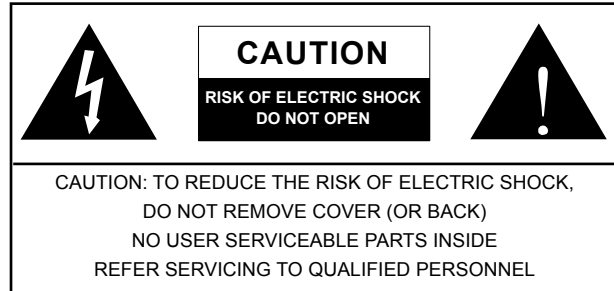

The lightning flash with arrowhead symbol, within an equilateral triangle, is intended to alert the user to the presence of uninsulated "dangerous voltage" within the product's enclosure that may be of sufficient magnitude to constitute a risk of electric shock to persons.



The exclamation point within an equilateral triangle is intended to alert the user to the presence of important operating and maintenance (servicing) instructions in the literature accompanying the appliance.

**WARNING:** To reduce the risk of fire or electric shock, do not expose this apparatus to rain or moisture.

**CAUTION:** Use of controls or adjustments or performance of procedures other than those specified may result in hazardous radiation exposure.



# POWERPOD 410

Powered Mixer

USER'S MANUAL

## TABLE OF CONTENTS

INTRODUCTION .....	4
FEATURES .....	4
GETTING STARTED .....	4
TYPICAL CONNECTING LEADS .....	5
CHANNEL STRIP DESCRIPTION .....	6
MASTER SECTION DESCRIPTION .....	6
REAR PANEL DESCRIPTION .....	7
APPLICATION .....	8
DIMENSIONS .....	10
SPECIFICATIONS .....	11
BLOCK DIAGRAM .....	12
APPENDIX .....	13

## INTRODUCTION

Congratulations on your purchase of the Phonic Powerpod 410 Powered Mixer. The Powerpod 410 is built into a rugged wooden cabinet for heavy-duty use. In order to get the best performance from your Powerpod 410, please read all of this safety and operation manual before operating the mixers and keep the manual for future reference.

## FEATURES

- 4 mono input channels for a wide range of Microphone and Line level signals from separate input sockets
- Built-in 100 watt power amplifier (max. output)
- Class D circuitry on built-in amplifier
- Built-in Digital Delay
- Super musical 2-band EQ at mono channels
- Record out
- Tape in with level control

## GETTING STARTED

1. Before turning on the power, set the Master output control to the off position.
2. Always turn the power off before connecting or disconnecting cables.
3. Check the AC Voltage before connecting the AC plug.
4. Do not obstruct the back panel at all for proper ventilation.

TYPICAL CONNECTING LEADS

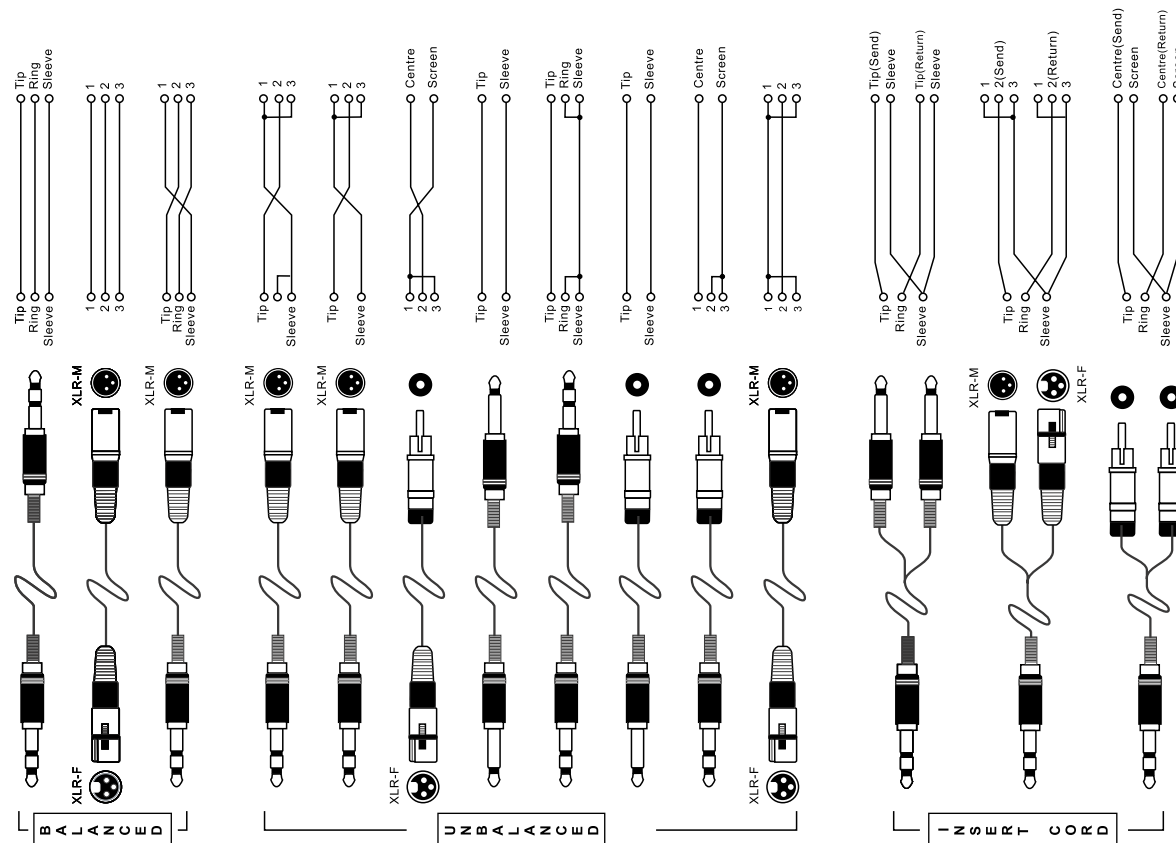
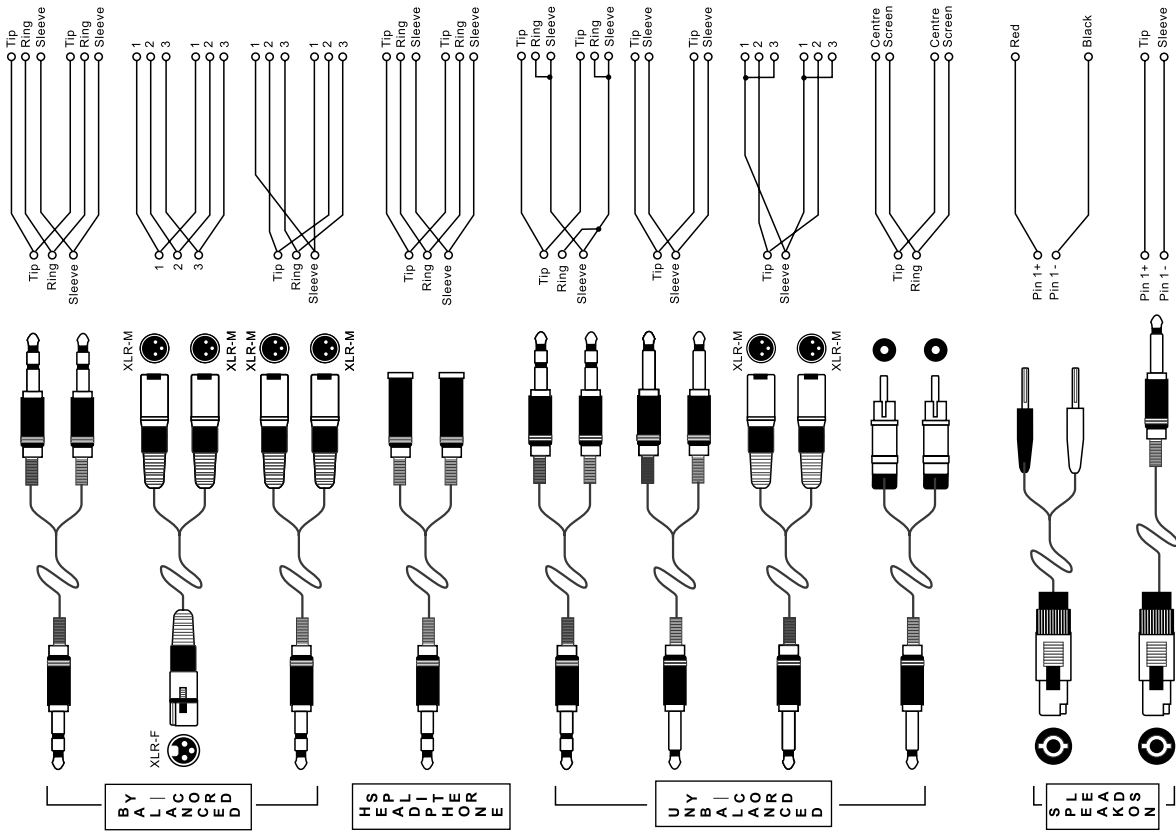

## CHANNEL STRIP DESCRIPTION

### 1. LOW EQ

The control has shelving response giving 15dB of boost or cut at 80Hz. Add warmth to vocals or extra punch to guitars, drums and synths by turning to the right. Turn to the left to reduce stage rumble, hum or to improve a mushy sound.

### 2. HIGH EQ

Turn to the right to boost high frequencies, adding crispness to percussion from drum machines, cymbals and synths. Turn to the left to cut these frequencies, reducing sibilance or hiss. The control has a shelving response giving 15dB of boost or cut at 12kHz.

### 3. LEVEL CONTROL

The Level Control determines the proportion of the channel signal in the mix, and provides a clear visual indication of channel level.

### 4. MIC & LINE INPUT

The MIC input accepts XLR phone jack while the LINE input accepts a 1/4" type phone jack. Please use a low impedance microphone and a properly wired cable for best results. You can only use one of the two connectors at the same time.

### 5. EFFECT

This knob decides the signal level which will be sent to the built-in digital delay effect control.

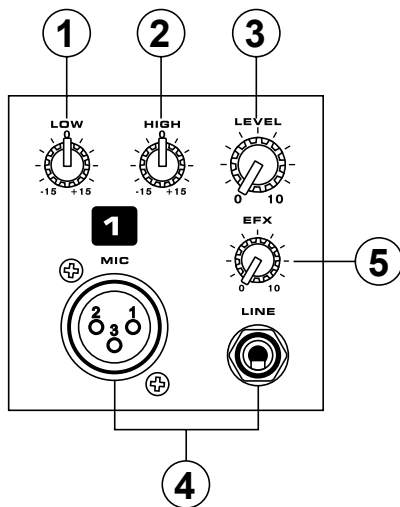

## MASTER SECTION DESCRIPTION

### 6. DIGITAL DELAY

The signal from the input channels, processed by the built-in digital delay will feed to the master output. There are three knobs here to control the effect of digital delay.

**LEVEL** - This knob adjusts the mix level of the effect sound.

**TIME** - This knob adjusts the internal time of the delays; turn to the right to increase the interval time between two delays.

**REPEAT** - To increase the rate of the delays, turn this knob to the right. You will hear the signal repeat at a faster rate.

### 7. POWER INDICATOR

When the power switch at the rear panel is turned on, this indicator will illuminate so the user may be aware of it.

### 8. TAPE IN CONTROL

This knob adjusts the level of signal from the Tape In to the Main bus.

### 9. MASTER CONTROL

This adjusts the final level of the Main bus. It controls the Main bus signal which is output to the speakers.

### 10. TAPE IN AND REC OUT

The TAPE IN sockets allow cassette recorders or CD players to be added to the Main output. The RECORD OUTPUT, with RCA phono sockets, provides signal output to a cassette deck and home audio equipment. The nominal output level and impedance are -10dBV/ 600ohms.

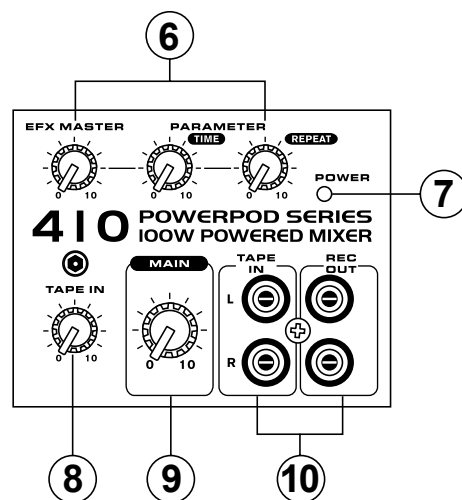

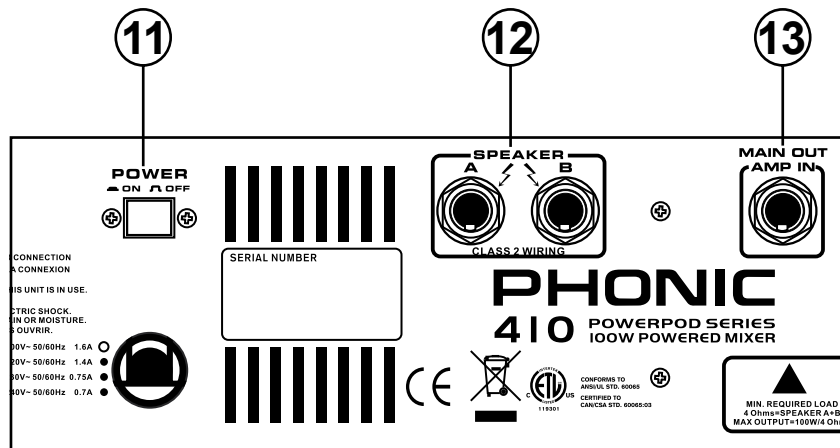

## REAR PANEL DESCRIPTION

### 11. POWER SWITCH

This switches the powered mixer on and off. While turn it on, the power on blue LED indicator will light up on the master section of front panel.

### 12. SPEAKER OUTPUT JACKS

Speakers can be connected to these sockets, two speakers can be connected to the powered mixer. When using 2 speakers at the same time, use 8~16 ohms speakers. When using one speaker only, use a 4~8 ohms speaker. The total minimum required load is 4 ohms. If the total load is less than 4 ohms, it may damage this powered mixer.

### 13. MAIN OUT / AMP IN

This unbalanced insert point is a break between the main out and built-in amplifier to allow the main output to be sent to an external signal processor or power amplifier. The insert is a 1/4" phone jack socket which is normally bypassed. When a jack is inserted, the signal path is broken.

The main output signal appears on the TIP of the plug and the external signal is returned on the RING. A "Y" lead may be required to connect to equipment with separate send and return jacks as shown below:

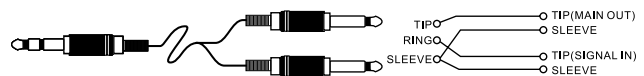

## APPLICATION GENERAL APPLICATION

### SPEAKERS

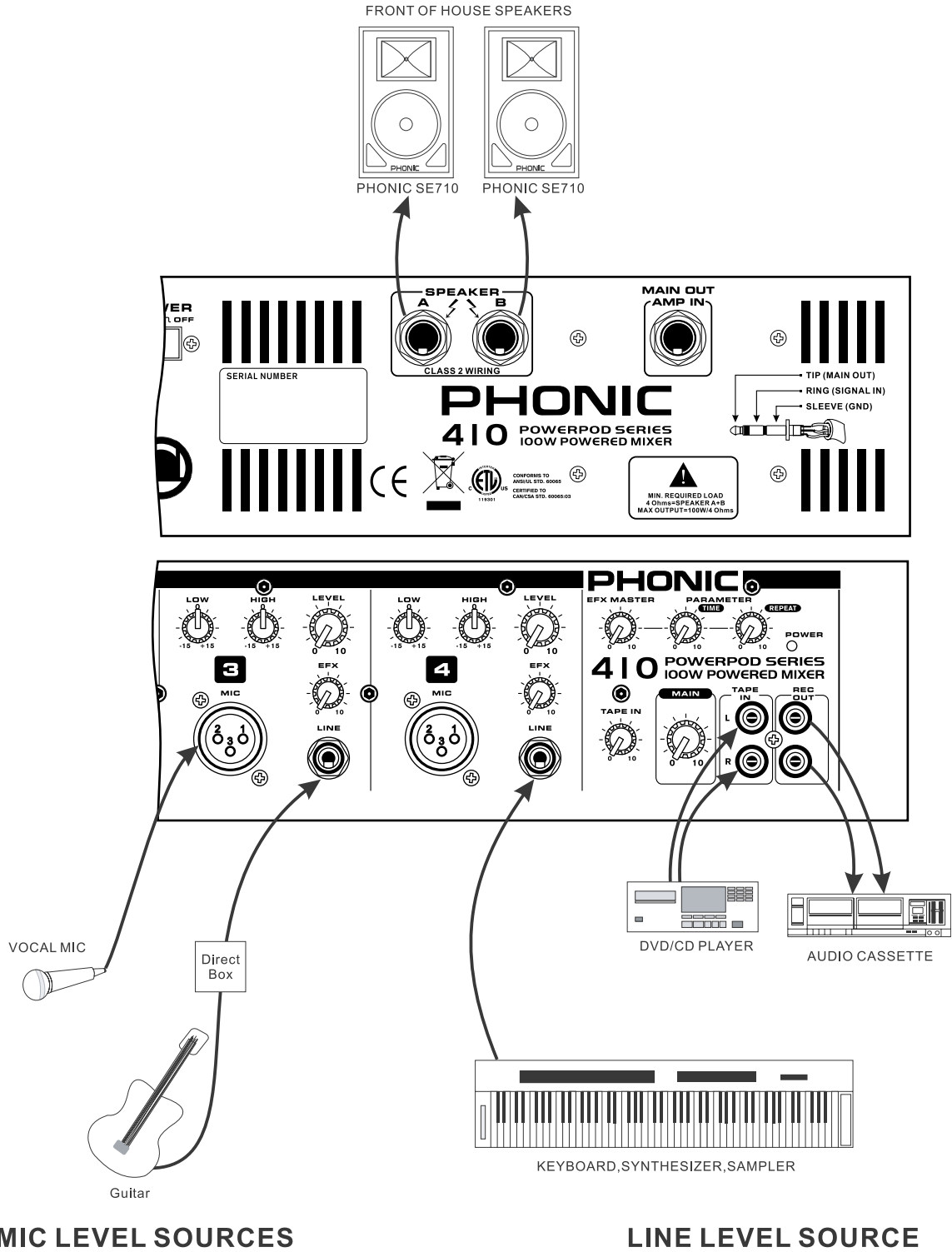

LIVE BAND WITH ADDITIONAL AMPLIFIER

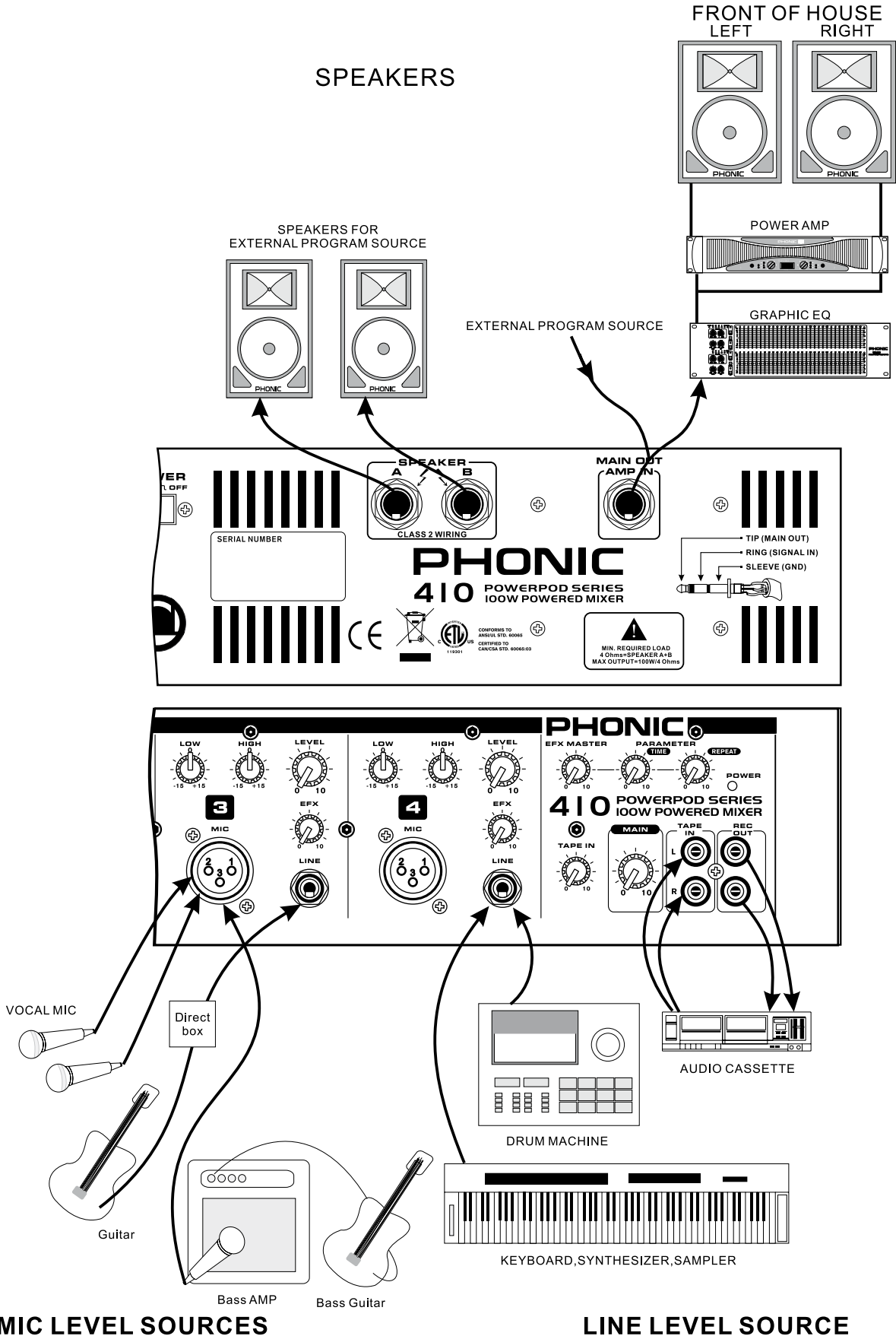

## DIMENSIONS

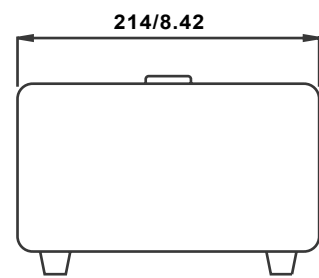
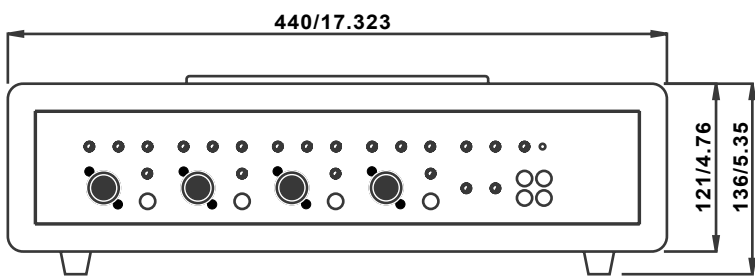
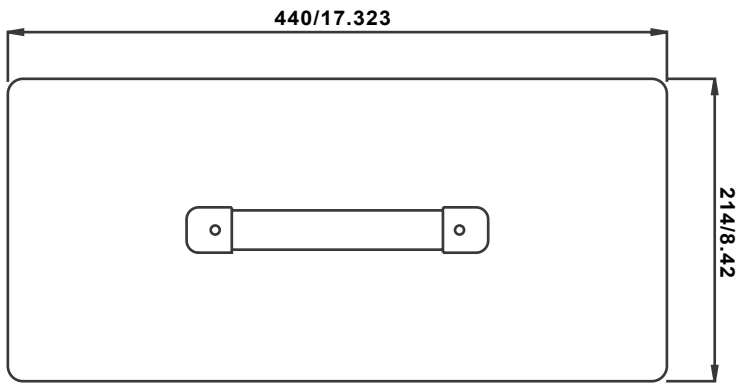

\* All measurements are shown in mm/inches.

**SPECIFICATIONS**

<b>POWER AMP, max. output power in watts</b>	
Number of Power channels	1
8 $\Omega$	65
4 $\Omega$	100
<b>Inputs</b>	
Balanced mono Mic/Line channels	4
2T input	1
<b>Outputs</b>	
Main out	TRS, unbal.
<b>Channel Strips</b>	4
Volume Controls	Rotary
<b>Master Section</b>	
Rotary Fader	Master
<b>Built-in Digital Effect</b>	Digital Delay (2ms-150ms)
<b>Noise</b> (20Hz to 20KHz bandwidth, line inputs to master output)	
Master output, all faders down	-86dBu
Power amp output, all faders down	-55dBu
<b>THD</b>	
Power output, 20Hz to 20KHz	@100 watts, 4 $\Omega$ <0.2%
<b>Crosstalk</b> (1KHz @ 0dBu, 20Hz to 20KHz bandwidth, channel in to master output)	
Channel fader down	<-63dB
<b>Frequency Response</b> (Mic input to output)	
20Hz ~ 20KHz, line level o/p @ +4dBu into 600 $\Omega$	+1/-3dB
20Hz ~ 20KHz, power amp o/p 1 watt into 8 $\Omega$	+1/-3dB
<b>Sensitivity @ mixer output +4dBu</b>	
Mic/Line	-50dBu/-35dBu
Tape in	-6dBu
<b>Channel Equalization</b>	2-band, $\pm$ 15dB
Low EQ	80Hz
Hi EQ	12KHz
<b>Microphone Preamp E.I.N.</b> (150 ohms terminated, max. gain)	<-122dBm
<b>Power Consumption</b>	110 watts
<b>Power Requirements</b>	100-120, 220-240 VAC, 50-60 Hz
<b>Dimensions(WxHxD)</b>	440.0 x 136.0 x 214.0mm (17.32"x5.35"x8.42")
<b>Weight</b>	7.2 kg (15.86 lbs)

## BLOCK DIAGRAM

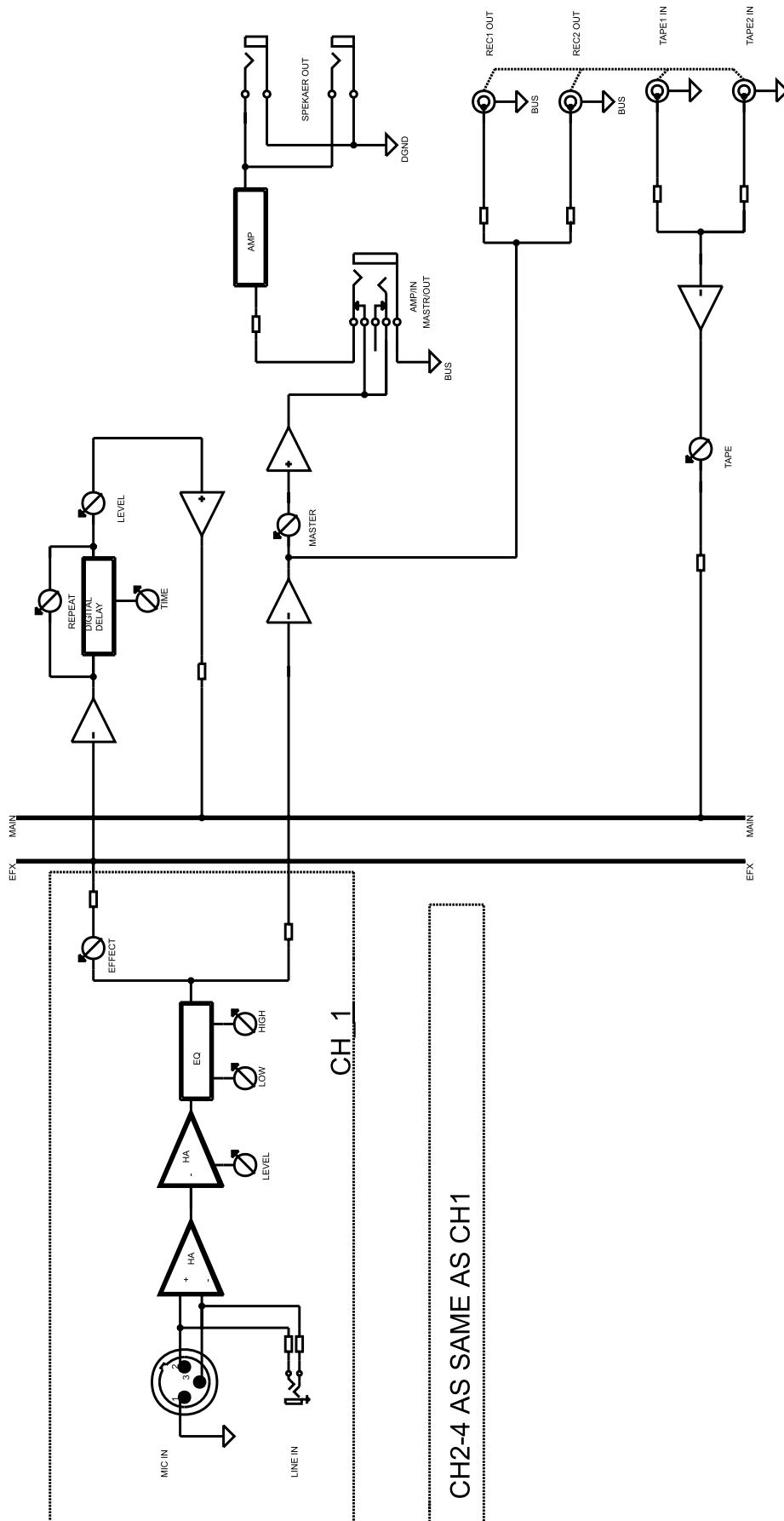

## APPENDIX

### Reference Books

Phonic recommends the following books for those interested in advanced audio engineering and sound system operation:

- Sound System Engineering by Don and Carolyn Davis, Focal Press, ISBN: 0-240-80305-1
- Sound Reinforcement Handbook by Gary D. Davis, Hal Leonard Publishing Corporation, ISBN: 0-88188-900-8
- Audio System Design and Installation by Philip Giddings, Focal Press, ISBN: 0-240-80286-1
- Practical Recording Techniques by Bruce and Jenny Bartlett, Focal Press, ISBN: 0-240-80306-X
- Modern Recording Techniques by Huber & Runstein, Focal Press, ISBN: 0-240-80308-6
- Sound Advice – The Musician’s Guide to the Recording Studio by Wayne Wadham, Schirmer Books, ISBN: 0-02-872694-4
- Professional Microphone Techniques by David Mills Huber, Philip Williams. Hal Leonard Publishing Corporation, ISBN: 0-87288-685-9
- Anatomy of a Home Studio: How Everything Really Works, from Microphones to Midi by Scott Wilkinson, Steve Oppenheimer, Mark Isham. Mix Books, ISBN: 091837121X
- Live Sound Reinforcement: A Comprehensive Guide to P.A. and Music Reinforcement Systems and Technology by Scott Hunter Stark. Mix Books, ISBN: 0918371074
- Audiopro Home Recording Course Vol 1: A Comprehensive Multimedia Audio Recording Text by Bill Gibson. Mix Books, ISBN: 0918371104
- Audiopro Home Recording Course Vol. 2: A Comprehensive Multimedia Audio Recording Text by Bill Gibson. Mix Books, ISBN:

## **TO PURCHASE ADDITIONAL PHONIC GEAR AND ACCESSORIES**

To purchase Phonic gear and optional accessories, contact any authorized Phonic distributor. For a list of Phonic distributors please visit our website at [www.phonic.com](http://www.phonic.com) and click on Get Gear. You may also contact Phonic directly and we will assist you in locating a distributor near you.

## **SERVICE AND REPAIR**

Phonic has over 100 service centers worldwide. For replacement parts, service and repairs please contact the Phonic distributor in your country. Phonic does not release service manuals to consumers, and advice users to not attempt any self repairs, as doing so voids all warranties. You can locate a dealer near you at [www.phonic.com](http://www.phonic.com).

## **WARRANTY INFORMATION**

Phonic stands behind every product we make with a no-hassles warranty. Warranty coverage may be extended, depending on your region. Phonic Corporation warrants this product for a minimum of one year from the original date of purchase against defects in material and workmanship under use as instructed by the user's manual. Phonic, at its option, shall repair or replace the defective unit covered by this warranty. Please retain the dated sales receipt as evidence of the date of purchase. You will need it for any warranty service. No returns or repairs will be accepted without a proper RMA number (return merchandise authorization). In order to keep this warranty in effect, the product must have been handled and used as prescribed in the instructions accompanying this warranty. Any tempering of the product or attempts of self repair voids all warranty. This warranty does not cover any damage due to accident, misuse, abuse, or negligence. This warranty is valid only if the product was purchased new from an authorized Phonic dealer/distributor. For complete warranty policy information, please visit <http://www.phonic.com>.

## **CUSTOMER SERVICE AND TECHNICAL SUPPORT**

We encourage you to visit our online help at <http://www.phonic.com/help/>. There you can find answers to frequently asked questions, tech tips, driver downloads, returns instruction and other helpful information. We make every effort to answer your questions within one business day.

**Phonic America Corporation  
6103 Johns Road #7  
Tampa, FL 33634  
(813) 890-8872  
[support@phonic.com](mailto:support@phonic.com)  
<http://www.phonic.com>**

# **PHONIC**

**PHONIC**  
[WWW.PHONIC.COM](http://WWW.PHONIC.COM)